

REV	DESCRIPTION	DATE

## NOTES

**MATERIAL** (ABS) FLAME RETARDANT UL94 VO MATERIAL WITH BRASS INSERTS IN CORNER POSTS,  
(STYRENE) IS NON-FLAME RETARDANT WITHOUT BRASS INSERTS.

**PARTS** (ABS) VERSION MACHINE SCREWS M3-0,5 x 28mm,  
REPLACEMENT PN 1599HMS100 (100 / BAG), (STYRENE)  
VERSION SELF TAPPING #4 x 1,3125",  
REPLACEMENT PN 1599HTS100 (100 / BAG).

**COLORS** (ABS) BLACK, & GRAY, (STYRENE) GRAY ONLY.

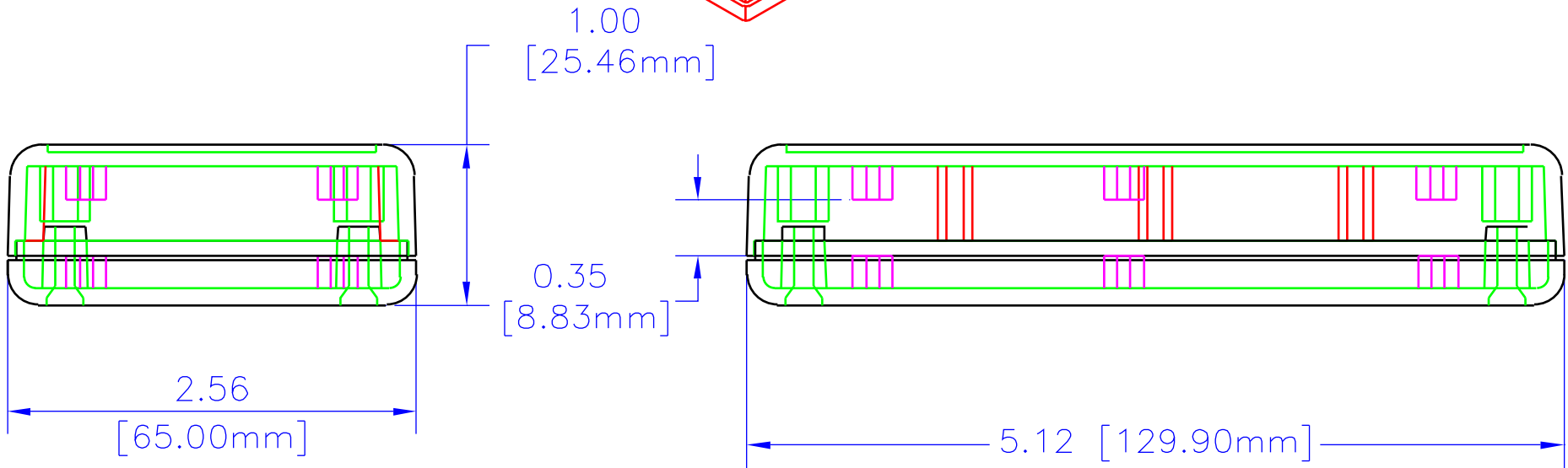
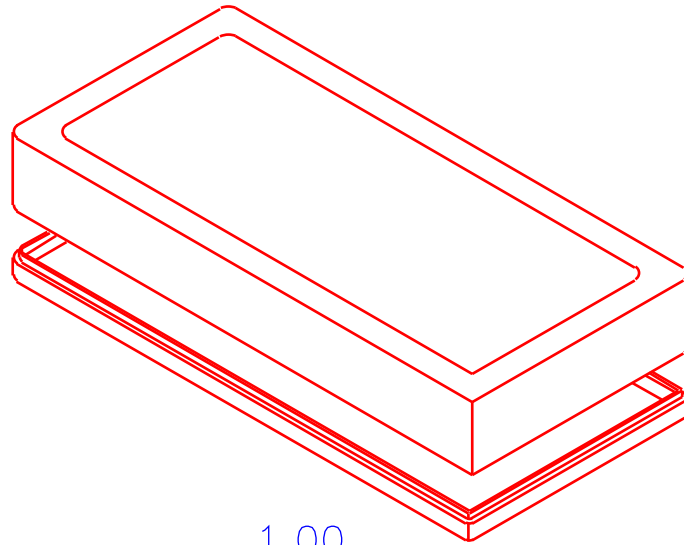

# ASSEMBLED

UNLESS OTHERWISE SPECIFIED  
DIMENSIONS ARE IN INCHES.

X +/- .1  
XX +/- .02  
XXX +/- .015  
SLITS +/- .005  
ANGLES +/- .5 DEG.

INCLUDE:  
HAMDONS LEAVES PROPRIETARY RIGHTS TO  
THE MATERIAL ON THIS DRAWING. IT IS  
INTENDED TO BE USED AS A REFERENCE FOR  
ENGINEERING INFORMATION ONLY. THIS  
INFORMATION MAY NOT BE USED TO  
MANUFACTURE PRODUCTS WITHOUT WRITTEN  
PERMISSION FROM HAMMOND MANUFACTURING.



**HAMMOND  
MANUFACTURING**

WEB: [WWW.HAMMONDMFG.COM](http://WWW.HAMMONDMFG.COM)

TITLE HAMMOND 1599 SERIES  
PLASTIC ENCLOSURE

DRAWN BY MJM DATE 07/30/01

SCALE PAGE 1 OF 3

PART NUMBER 1599B

# NOTES

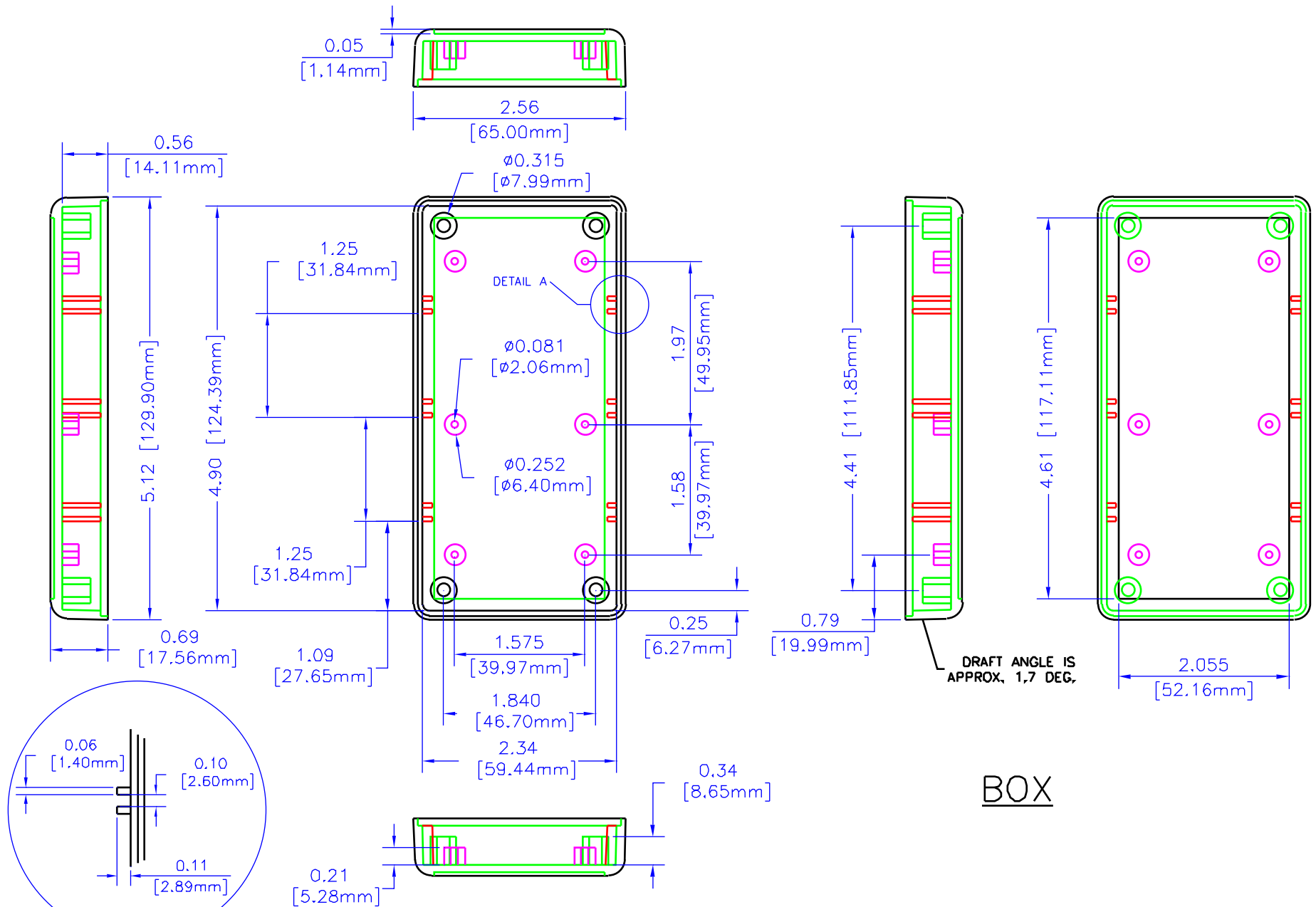

BOX

UNLESS OTHERWISE SPECIFIED  
DIMENSIONS ARE IN INCHES.  
X +/- .1  
XX +/- .02  
XXX +/- .015  
SLITS +/- .005  
ANGLES +/- .5 DEG.  
INCLUDE:  
HAMMOND MANUFACTURING PROPRIETARY RIGHTS TO THE MATERIAL ON THIS DRAWING IS RESERVED. IT IS INTENDED TO BE USED AS A REFERENCE FOR ENGINEERING INFORMATION ONLY. THE INFORMATION MAY NOT BE USED TO MANUFACTURE PRODUCT WITHOUT WRITTEN PERMISSION FROM HAMMOND MANUFACTURING.



**HAMMOND  
MANUFACTURING**

WEB: WWW.HAMMONDMFG.COM

TITLE		HAMMOND 1599 SERIES PLASTIC ENCLOSURE	
DRAWN BY	MJM	DATE	07/30/01
SCALE		PAGE	2 OF 3
PART NUMBER	1599B		

# NOTES

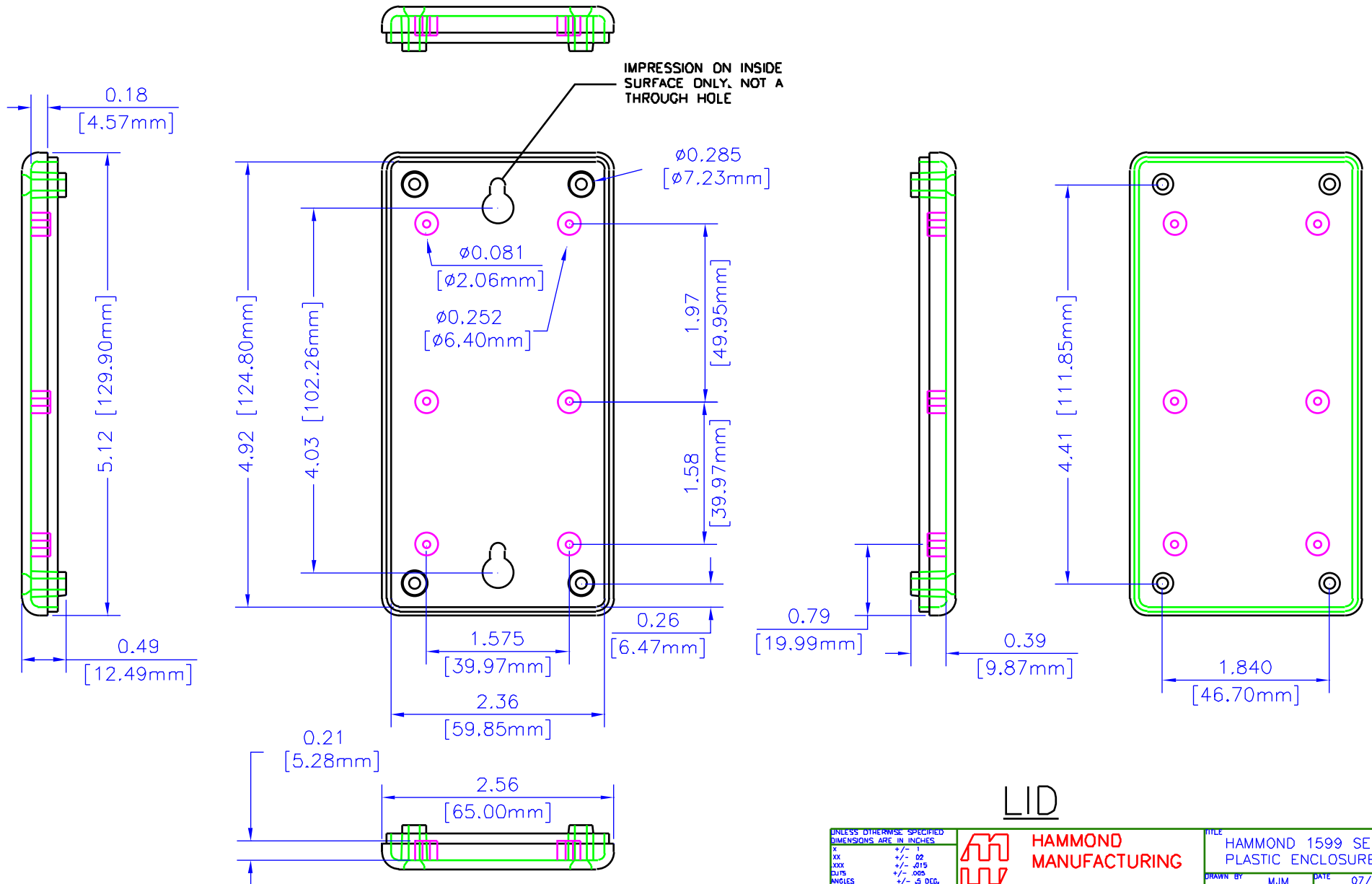

LID

UNLESS OTHERWISE SPECIFIED  
DIMENSIONS ARE IN INCHES.  
X +/- .1  
XX +/- .02  
XXX +/- .015  
SLITS +/- .005  
ANGLES +/- .5 DEG.  
INCLUDE:  
HAMMOND MANUFACTURING PROPRIETARY RIGHTS TO  
THE MATERIAL ON THIS DRAWING IS  
RESERVED TO BE USED AS A REFERENCE FOR  
ENGINEERING INFORMATION ONLY. THE  
INFORMATION MAY NOT BE USED TO  
MANUFACTURE PRODUCT WITHOUT WRITTEN  
PERMISSION FROM HAMMOND MANUFACTURING.



**HAMMOND  
MANUFACTURING**

WEB: WWW.HAMMONDMFG.COM

TITLE		HAMMOND 1599 SERIES PLASTIC ENCLOSURE	
DRAWN BY	MJM	DATE	07/30/01
SCALE		PAGE	3 OF 3
PART NUMBER	1599B		